

Enric Miralles' Architectural Pieces: Three Exemplary Attempts

JOSÉ VELA

Abstract

The status of an “unbuilt idea” is a dubious one. It presupposes, in the first place, the existence of something as elusive as “architectural ideas”. Moreover, it disconnects architectural thinking from its materialization, either implying that ideas are not embedded in architecture only or that architecture can only be found in built buildings —erasing the ideas in the process. Finally, it takes away from architecture its capacity of awakening, of production versus mere reproduction. Of course, none of these assertions are quite right —though none are totally untrue. This paper will explore three architectural pieces designed by architect Enric Miralles around the mid-1990s in search not of an answer to the abovementioned questions —which will be impossible in the limited amount of space of this article— but of a demonstration, in the sense of a presentation, of the complexity of the task. Three architectural pieces radically different but nevertheless coherent as a group, of a rather uncanny quality —being architecture, are neither buildings nor ideas— will be presented in their exemplar quality: they are exemplar —even paradigmatic— constructions precisely because they are not buildings and remain unbuilt. No conclusions should be expected, even if the endeavor is worth the attempt.

Keywords

Enric Miralles, ideas, unbuilt, pieces, drawing, play.

José Vela Castillo es arquitecto (ETSAM 1992) y doctor arquitecto (ETSAM 2000). DEA Facultad de Filosofía (UCM, 2006). Actualmente es *associate professor* de Culture and Theory in Architecture e Idea and Form en IE University. Investiga sobre filosofía y proyecto de arquitectura desde un pensamiento postmetafísico y desde una actitud de resistencia. Su investigación actualmente se centra en la condición paradigmática del proyecto de arquitectura y en la definición de una performatividad netamente arquitectónica. Ha publicado recientemente artículos en *[i2]* (2015), *REIA* (2015), *Escritura e Imagen* (2014), *Desierto* (2014), *Conditions* 13 (2014) y *Architecture and Culture* (2013) y ha presentado sus investigaciones recientes en numerosos congresos y conferencias internacionales (JIDA-Barcelona 2015, AIARG-Dublin 2015, Writingplace-Delft 2013, Knowing by Designing-Bruselas 2013). Es miembro fundador de *Intersección* (Grupo de investigación de filosofía y arquitectura) investigador en el proyecto *Espacio y subjetividad: ampliaciones y quiebras de lo subjetivo en la ciudad contemporánea*, concedido por el Ministerio de Educación y Ciencia. En 2004 publicó el libro *Richard Neutra. Un lugar para el orden* (Kora, Universidad de Sevilla) y en 2010 el libro *(de)gustaciones gratuitas. De la deconstrucción, la fotografía, Mies van der Rohe y el Pabellón de Barcelona* (Abada).



[Fig. 1] Enric Miralles y Eva Prats, "Como acotar un croissant": El croissant/The croissant. Publicado/Published en/in *El Croquis* 49-50, 1991.

Is it really possible to build an idea? And how should an idea look like if built? What happens to unbuilt ones, poor and second rate sisters, lacking in substance, in constructive presence? They do exist, really? Do they remain unbuilt due to lack of funding, technical difficulties, and forgiveness of desire? Or are they finally unbuilt because architectural ideas cannot, by their own nature, be materialized into something as a regular building, a constructed artifact, an object of architectural desire? Objects of desire they are, those ideas, the unbuilt ones and the tentative ones, those elusive, fictional, intransitive ruminations, neither buildings as such nor mere illustration of buildings, yes, of course, objects of desire, without existence different than their being *in construction*. Thus, ideas are objects of desire, either built or unbuilt —before or after construction—, calling and calling again for their own presence, for a sign and track of an appearance, for becoming substantial, for *being-in-construction*. Yet architectural ideas do not exist by definition (in name); there is only the desire, if so. Nothing exists on the outside, in the proper realm of architecture, to which they can be referred to as pre-existing model to copy, no final or perfectly finished object arrived at by way of the model or idea. Only the desire, to say it again, and the insatiable two-way movement of materialization and dematerialization that pervades any process of *pro-jection*, only the desire but never a lack, qualifies absence as existential rite for being. As for example, the idea and the artifact...[figure 1]

The status of architectural ideas always has been a controversial one. But it is especially complex when dealing with Enric Miralles, when the issue is to define the relationship of abstract thought to his architecture. The point is that they propose a particular pairing with construction, or better said, with building; because they have not any particular agency of their own different than being, actively, in *construction*. Or in other words, the question of architectural ideas — built *and* unbuilt — helps us to understand the question of, precisely, in which sense we can say that Enric Miralles' architecture is *unbuilt*. What I propose in this paper is that, on the one hand, and following the convention of what built architecture is, his architecture is, precisely, never built; while on the other hand, and as consequence, the designs, drawings, montages, collages, models and furniture designs, drawn and written ruminations he produced with feverish fruition, were of the same authority as his standing buildings. They were that paradoxical something called, properly or not, *unbuilt architecture* — and in combining both words, *unbuilt* and *architecture*, there is a confluence of substantiation and de-substantiation. In that sense, and focusing on three projects that are not conventional buildings (the exemplary architectural pieces of the title) this paradoxical and undecidable relation to building becomes a lesson toward unraveling category errors in the focus of architecture on built works.

The final point is: there are not unbuilt ideas since ideas are not separable from the process of being built (or constructed), either in drawings or models or in actual buildings. And Miralles' architecture is the perfect demonstration of this *process*. By focusing in designs that are not buildings, but small scale pieces and drawings, by leaving outside the equation the *functional* issue (site, program, budget, regulations, construction, engineering, the client and so on), I am only trying to touch the bare bone of Miralles' architecture, his private cooking so to speak.

Saying that his buildings —the "real" constructed and photographed ones—are *unbuilt*, of course, demands some explanation. The first thing to clarify is that the word "building" does not denote the finished and stable object that usually is thought of, but in Miralles' architecture, always a provisional construction that only accidentally cancels its process of coming into being —the scaffolding disappearing and the workers temporarily sent home, the client thinks that he or she possesses a finished building. Even the insurance company believes that a signature on a sheet of paper marks the end of something...— and that, nevertheless, is still open

JOSÉ VELA

Enric Miralles' Architectural Pieces:

Three Exemplary

- 1 Enric Miralles in Alejandro Zaera-Polo, "A Conversation with Enric Miralles", *El Croquis* 72 [II] (1995): 18. Of course many scholars tackled the issue of the "unfinished" condition of Miralles' design process and his buildings, a question to which Miralles himself came back to repeatedly. But what I want to stress here is that what it precisely means is that his designs are immanently unbuilt. Unfinished never means a possible completion (even in a distant future), a closed work; it always means that the unbuilt is, at the very least, as important as what is constructed, but also that what is actually built signs the track and the mark of what is not actualized. And it is this mark, this trace of "what it is not," that determines what oddly exists as unbuilt object: a fractured entity, a disjointed place. An unfinished building is haunted by a specter, and this specter, always unexpected, forbids any possible closure of the building. Enrique Granell specifically put in relation the idea of "unfinished work," with the book written by Raymond Queneau, *Cent mille milliards de poèmes* ("Hundred Thousand Billion Poems"), an author admired by Miralles. The book is a set of ten sonnets, each line printed in a separated strip so that they can be recombined to form the impressive "hundred thousand billion" of the title. I think this reference miss the point, since, at the end, it implies a defined number of possibilities, a closed work formed by the total number of permutations. This is not an "infinite" book as Granell says: it is only a super-supersized one. The reference, instead, needs a different genealogy, that should be traced back to Stephane Mallarmé and his tentative and elusive project "The Book" (*Le Livre*) via Maurice Blanchot (rather than this particular book by Queneau. Josep M. Rovira adequately relates Miralles' idea of the unfinished to Blanchot. See Josep M. Rovira, "Acercarse", in Josep M. Rovira (ed.), *Enric Miralles, 1972-2000* (Barcelona: Fundación Caja de Arquitectos, 2011), 12 and 18-19. For Blanchot, every literary work, or even the literary work as a whole is an unending task, in the form of a conversation (with the Other), as he, for example, elaborates in *L'Entretien infini*. In that sense, for Blanchot, the work that remains to be done (the not-yet of the work) is the essence or the very being of the work. See Maurice Blanchot *L'Entretien infini* (Paris: Gallimard and NRF, 1969) and Carolyn Bailey Gill (ed.), *Maurice Blanchot. The Demand of Writing* (London and New York: Routledge, 1996), especially the article included in the compilation by Paul Davies, "The Work and the Absence of the Work" (c.f. page 92). I elaborated on some of the relations between Mallarmé and Miralles in a paper presented at the *Writingplace* conference (TU Delft, November 2013) entitled, "Le

to future reconfigurations. There are many statements of Miralles in that direction. Let's quote the following, in which he insists in the unbuilt condition of the work:

"I told you before that for me, a work is never completed; it is almost a way in which the building itself retains its scaffolding permanently, in its very nature."¹

And also: "[...] to never understand projects as terminated pieces."²

It should be added to clarify that I equate here "unbuilt" and "unfinished" in an apparently misguided equivalence meaning that his buildings have not a determined temporal horizon in which they can be finished, as if in the designs the architect foresees a particular configuration of the architectural piece as a complete and self-sufficient standing object — a lifeless corpse. The buildings remain unfinished because they are unbuilt — and the other way around. There are always many other buildings that can be the result of the same project, there are multiple other configurations that can be constructed after the same design process, there are second lives of some buildings inside of others, one design morphing into many others precisely because they are never built...³: Miralles' buildings are multiplicities, and the state of actualization of some of them does not preclude the erasure of the others.⁴ They coexist — even at the same time. They, only, remain unbuilt, yet. In that precise sense, an unfinished building is an unbuilt one. Or in other words: they are unbuilt in the sense that those designs, those ideas-in-progress, although always pointing towards its construction, can never be exhausted in construction itself, they are not, as Mark Wigley puts it, "absorbed by the act of building itself."⁵

The second point to examine lead us back to the question of architectural ideas, and to what such ideas are or are not—a chiasmus that is probably impossible to define—, at least to what ideas are not—for him: to trace them *via negativa*. It should be repeated, then, that in Miralles' work there is nothing we can call unbuilt ideas, since ideas do not exist previously to its materialization. They do not exist in a separated and eternal ether from which the architect can take and reintroduce them into the perceptive realm of matter (the Platonic argument), perfect models of architectural permanence ready to copy as paradigms into the contingent world do not exist as such.⁶ And it is this very non-existence that stymies all attempts to rationalize Platonic exegesis (since it never was meant as a working model for artistic creation but, instead, a means for ideational reflexion). Thus, there is something in the work of Miralles that is a continuous campaign *against* such misreadings of Platonic mimesis.⁷ But neither are they the result of the unfolding of spirit into the physical realm of the world, in a seemingly Hegelian fashion, implying a finalist attitude and a preference for a finished object transformed into a desirable goal, the result of this unfolding, as an end in itself — a reified object of desire and the Ideal made Real. What in the first conception was "at the beginning" seems to be put "at the end" in this second one — "Plato to Hegel" signifying some sort of categorical error in judgment for modernity. Yet in both cases the shot fails its target for very good reasons: architectural ideas do not have an existence distinct and separate from architectural being, the process of designing, building, and experiencing architecture, accordingly, inclusive of the built/unbuilt dialectic otherwise denoted through terms such as autonomy, praxis, and theory.⁸ This in turn suggests that both the Platonic and Hegelian analogues, as above, do not apply to design arts as such, insofar as design arts already play with the Real (versus simply re-symbolize it or problematize it in relation to "coming into being") — or because, as Hegel suggested, architecture is rarely speculative intellect proper and thus not quite free to be called "free". And this hundred-year-old-plus insult to architecture is yet to out lived only because the Platonic remainder plagues architecture's bad conscience (its incessant complicity with power and instrumental reason for all the *wrong* reasons).

livre de l'architecture Stéphane Mallarmé, Enric Miralles and the question of scripture" (unpublished). I do not have space to expand this unending conversation here, but it is an important one to follow. It should also be extended, at least, to the work of Edmond Jabés and Jacques Derrida..

- 2 Enric Miralles in Alejandro Zaera-Polo, "A conversation with Enric Miralles", *El Croquis* 72 [II] (1995): 11.
- 3 One paradigmatic example is the appropriation in the Camy-Nestlé bridge of part of the Aulario for the Valencia University, that as Rafael Moneo says is a translation of the bridge in La Mina and that will resurface years later in the University of Vigo. Says Miralles: "Perhaps the most extreme case is the Camy-Nestlé bridge project, which is built from a literal shift of one piece of the project for the Valencia Classroom Building which was never constructed." See Enric Miralles in Alejandro Zaera-Polo, "A conversation with Enric Miralles", *El Croquis* 72 [II] (1995): 12. See Rafael Moneo "[An intense life, a consummate work] Enric Miralles" in *El Croquis* 100-101 (2000): 311.
- 4 Insisting on the same idea, Miralles says to Zaera-Polo: "I think it has to do with a very deep conviction that projects are never completed. They rather enter successive stages in which maybe we no longer have direct control over them, or perhaps they are reincarnated in other projects we design..." Enric Miralles in Alejandro Zaera-Polo, "A conversation with Enric Miralles", *El Croquis* 72 [II] (1995): 12.
- 5 Mark Wigley, "After-Life in Progress" in *El Croquis* 144 (2009): 9.
- 6 As Miralles says, "[...] one of the most characteristic things about my style of work is that I never have a prior idea of the space I am trying to construct". In Alejandro Zaera-Polo, "A conversation with Enric Miralles", *El Croquis* 72 [II] (1995): 15. There are not, then, anticipations, or visions, architectural illusions that prefigure the finished outlook of the architectonic space. In fact, Miralles' architecture precisely works against this idea of "envisioned space", or even, some argue, against the very (modern) idea of space as the real subject of architecture. In that sense, Enrique Granell says the following: "The expression of space was one of the goals of modern architecture. Understanding architecture in that sense had reached the point in which no existence other than the spatial one was considered. Miralles proves this claim wrong..." Translated by the author and Diego Bernalte Arenas. Enrique Granell, "Singladura de instantes. Nueva sede cultural del Círculo de lectores de Madrid" in *DC Papers* 17-18 "Enric Miralles 1955-2000" (2009):158.
- 7 This relates closely with the already advanced belief in never understanding projects as finished objects, a notion which radically destabilizes the mimetic condition of architecture: "That is why I am increasingly interested in displacements as a technique. In essence it is a technique to break off from *mimesis* as the fundamental operative basis of traditional architecture. Accepting the mimetic

The third important point explicitly puts in relation building and un-building (or non-building) in the form of the ruin. Projects, designs, and buildings are not only unfinished works, but they are also ruined works in Miralles' thought. The ruin, obviously, is not a degraded state for a building (or of a pristine idea) but its very essence, since it is part and parcel of the endless dialectic of building-unbuilding in which Miralles' projects and buildings are ensnared.

Hence, to understand the project the architect is working in, to design and to build it, it is necessary to foresee the destruction of this very same building, its simultaneous ruination. To find the actual, temporary form that it will have in the moment of its construction, it is compulsory to know its ruined inner core from the outset. It needs to be literally "un-built" (which means also deconstructed and de-sedimented, but not only), the opposite action of "to build": the knots of the woven architectural fabric need to be disentangled and reordered, rearranged in their many "un-built" or "un-knotted" possibilities, examined in their ultra-contingency in order to unveil their most likely present configuration, to allow the very construction to take place — and take time. To understand and to produce the design, it is necessary to, literally, un-build it as well. Writing a year after the roof of the Huesca Sport Palace fell to the ground during construction, when the project was redesigned and close to temporary completion, Miralles explained: "I have so often depicted the destruction of a building to find what its form was, or to make what its process of formation — its making — had been." And shortly after: "Imagining the destruction and ruin of a building leads to the intermediate moments of construction. Ruin is a parallel process to construction ..."⁹ Ruin is a precondition of building. It is not only the opposite process to building (a ruin is not a permanent state, but a continuous process), but its double. Not its nemesis, ruination is its condition of possibility as a quasi-transcendental something. The un-built is to architecture what form-giving is to the process of building architecture. This discord produces the architectural object.

The consequence of this is that Miralles understands the process of building (of building the design and constructing the drawings, that we said are already architecture but also of physically erecting the building) as a process of un-building. Project, building, and ruin are not separate realms, but part of the very same process of construction-destruction, of coming to presence and vanishing-reconfiguring into not-yet-presence, of building-unbuilding. There are not two different processes: to build is necessarily, even physically, to un-build.

The dividing line between the before and the after, between the built and the not-yet-built architecture, between building and — its — ruin is thin ice in Miralles' work, but it is necessary to acknowledge that he skates with aplomb and elegance, with the slightly old fashioned but so delicious wittiness of a Fred Astaire sliding through the dancing hall — Ginger Rogers' vaporous skirt blurring the transcendental divide between actual and virtual, between still and not yet and the actual. Performing, so to speak, his game of touching and not touching the surface, the polished surface in which events materialize, the screen, the medial surface of presentation-disappearance in which Miralles' ideas hover and flicker for a moment, so rapidly that nearly no mechanism can apprehend them, except, of course, the — slowest — mechanism of architecture: drawing *and* construction. That is, de-construction.

Curiously enough, this insistence in the unbuilt essence of his architecture obviously attacks and devaluates the architectural object as a finished entity with stable and permanent meanings, the traditional and even modern status of architecture as a fine art the result of the creative effort of an author (contra Hegel's demotion of architecture, as above), addressing the question of authorship in a clearly

JOSÉ VELA

Enric Miralles' Architectural Pieces:
Three Exemplary

postmodern way. Since the buildings are unbuilt, who can claim to be the author of something that is not finished, nor even “made”? But at the same time, the heroic figure of Miralles reintroduces the myth of the formidable artist-creator, the modern demiurge in its protean complexity who is capable of such enormous creative force that overcomes, time and again — although temporarily — the unstoppable tendency of buildings to, precisely, unbuild themselves giving them *his* signature.

Three dances with the exemplary

In any case, the question concerning our examples, rests: are they built or unbuilt? And if so, in what sense?

Of the three pieces that will be reviewed, at least one (the first, “Cómo acotar un croissant,” “Dimensioning a Croissant” or “How to lay out a Croissant” from 1991), following the architectural conventions is radically unbuilt —since it is a drawing that only can be a drawing, nor a design to be reproduced but a design that is a direct reading of the real; it is therefore not intended to be transformed into an architectural artifact —though it does not really mean it is not *constructed*. Another, the second (the “Mesa Ines-Table” or “Ines-Table *table*” from 1993) is a mobile construction in no given fixed place: a single —but repeatable— piece of furniture. An exemplar table never identical to itself is left nevertheless as an artisanal structure never to enter furniture production as such. It poses the ambiguous relation with construction and with building of a displaced interior space, exploring uncannily the complex relation with the existing “environment”, and exhibiting a surprising capacity to unbuilt it. The third and last one (“Kolonihaven” from 1996), a tiny children wooden house, was originally not built for the time, place, and purpose it was designed, yet a replica-variation exists today —and many more can be thought of. All three, in its absolute contingency, clearly pose the question of how designs can be both done and undone.

or repetitive condition of things is a value —it is hard to sustain today.” Enric Miralles in Alejandro Zaera-Polo, “A conversation with Enric Miralles”, *El Croquis* 72 [II] (1995): 11. Translation slightly modified by the author.

- 8 And in that particular sense, in contradiction to what is already said in note 6, Enric Miralles conception is absolutely modern, as developed in the different avant-garde movements at the beginning of the 20th century in their strenuous fight to free the work of art of any previous and alien content —distinct from the material content of the work. The point here is that for Miralles what is proper of architecture is not space in itself, but instead construction as process and history as genealogy. See some interesting reflections by José Quetglas concerning Miralles and the autonomy of modern art in José Quetglas, “Don't be deluded” in *El Croquis* 49/50 (1991): 22-23.

- 9 The quotation comes from the text written by Enric Miralles accompanying the publication of the Huesca Sports Palace in *El Croquis* 70 (1994): 36. For a discussion of the concept of destruction in Enric Miralles in a different context see Carolina B. García Estévez, “Lo sólido no se disuelve en el aire. Edificio de Gas Natural 1999-2008” in *DC Papers* 17-18 “Enric Miralles 1955-2000” (2009): 207-230
For a discussion of the concept of ruin in architecture see José Vela Castillo, “El tiempo de la arquitectura: ruina, archivo, fecha” in *Iluminaciones* nº3 (2011): 36-47.

Consciously, the selection is aimed to unveil, by addressing a significant but “minor” part of Enric Miralles’ production, the complex texture in which building and unbuilding, appearance and disappearance, weft and warp of the texture of the world, are entangled into an inseparable compound. That of architecture. In that sense, by reducing architecture to its minimum (materiality, structure, program, durability, the social and so on), it is easy to understand the complex relation of Enric Miralles work in relationship to ideas, construction and, at the end, pure architecture. Or so it goes the song.

What follows is the dazzling dangling flickering impossibility of its edification: both its exemplarity and its (un)construction. Let’s move, then, to the four “Enric Miralles’ Architectural Pieces”.

But first and lastly in this introduction, a semantic consideration: *Pieces* refer to its small scale —ranging, as advanced, from drawings to furniture to installations or small scale jolly constructions—, to its not being part of a bigger entity or totality, which is not to say that they are fragments —although some of them exhibit a fragmentary condition— if by fragments we understand the scattered remnants of a former unity— but research devices, necessarily incomplete by its own definition, part and parcel of a bigger but not yet closed or defined set (Enric Miralles’ designs). For Miralles there is particular relation between the identity of each particular piece of a design (and his designs are always a compound of multiple pieces) and a non-existing totality of which they are part too; he worked constantly with fragments in the sense that he used semi-autonomous pieces, recognizable in themselves, that he constantly reorganized into bigger compounds that are neither a mere aggregation of unrelated parts nor a hierarchical organized system. Consequently,

[Fig. 2] Enric Miralles y Eva Prats, "Como acotar un croissant": Planta y secciones A-E/ Plan and sections A-E. Publicado/Published en/in *El Croquis* 49-50, 1991.

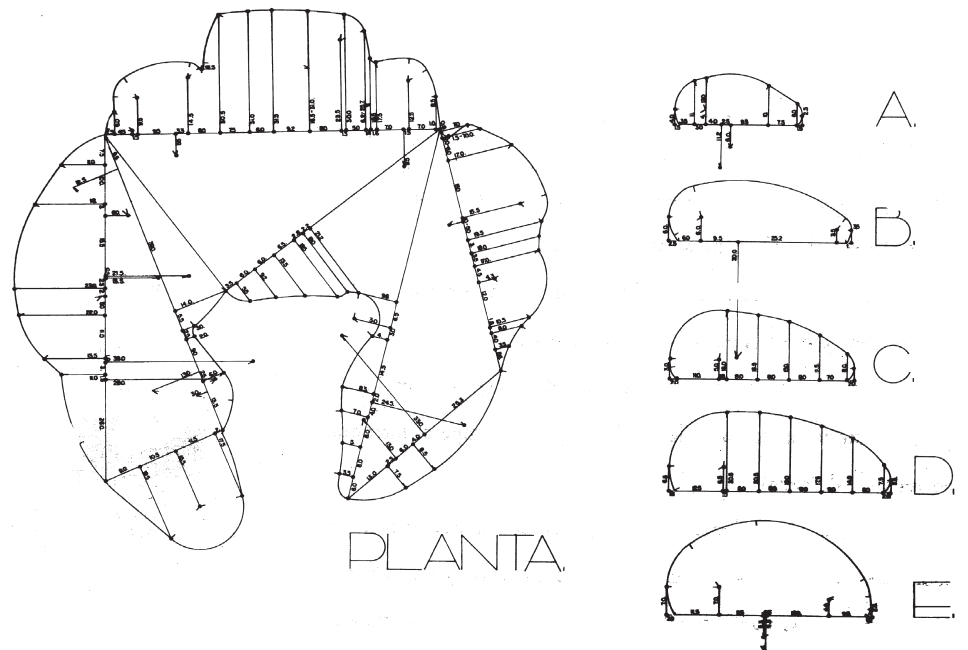

each piece, each design and each part of the design has its autonomy, and this allow this pieces to reappear in different contexts, even isolated, without being perceived as de-contextualized fragments. Says Miralles: "I like the pieces to have a recognizable character of their own, so that they can be removed from everything without completely losing their identity."¹⁰ This is very important, because even if he worked constantly with local conditions, individual occasions rather than general abstractions, there is an overall consistency in his work that calls for a kind of universal claim.¹¹ In that sense, this pieces are at the same time particular solutions to given situations (a drawing, a table, a house for children) and coexistent threads in the texture of the world. In some sense, this means that Miralles engages in every project as if he feels compelled to design a particular, small parcel of the world, as an example of how this same world will look like in full bloom.

But pieces, in Spanish, are also the different parts or components of an artifact, of a machine. Having the drawings some close resemblance to the technical drawings of engineers —describing a mysterious and not-yet-clear-for-what-use device—, and the pieces themselves an undoubted similitude with machines, they do seem to propose a particular machinic productive assemblage. They look like parts of a complex mechanism, of a gigantic but nearly dismantled universal machine. Following this thread will take too much time; it will need lengthy detours especially on Deleuze and Guattari, but also on Foucault and Agamben, and of course Benjamin and Adorno... not to forget the love Miralles had for Paul Klee and his so many "mechanical" objects present in his painting and drawings. But apart from those unavoidable references, I would like to think in allegorical mood to those Buicks and Cadillacs still patrolling the streets of Cuban cities, made as a conglomerate of spare parts coming from many different places, actual ruins slowly moving through The Malecón, made up of the ruined remnants of countless ancestors, and nevertheless alive and well as the first day, glaring as time-machines under the hot Caribbean sun. Miralles' pieces are like the spare parts *and* the ruined-reconstructed assemblages that put them back to life.

Finally, "pieces" refers to its playful or performative condition, since they are "pieces" in somewhat the same sense than when we speak about a theatre *piece* or a musical *piece*, and this is also a productive metaphor that deserves to be taken into account. Although, as Quetglas reminds us, there is a substantial difference with the "playing" of an actor or a musician: those are limited in time. The play Miralles' architecture stages is not: to our advantage, is unending, never running short of ground chocolate.¹² [figure 2]

10 Enric Miralles in Alejandro Zaera-Polo-Polo, "A conversation with Enric Miralles", *El Croquis* 72 [III] (1995): 17.

11 This can be linked to Jarry and Pataphysics, as Enrique Granell points, because, as Granell explains "[T]he science of Pataphysics is devoted to the study of particular cases because the world is a set of particular cases, and it must propose imaginative solutions for each of them." Enrique Granell, "Una maleta llena de arquitectura" in Josep M. Rovira (ed.), *Enric Miralles, 1972-2000* (Barcelona: Fundación Caja de Arquitectos, 2011), 45. Translation by the author.

12 Josep Quetglas, "From *Vers une architecture* to the first volume of *Oeuvres complètes*", in *El Croquis* 100-101 (2000): 28-29. And, of course, Duchamp.

JOSÉ VELA

Enric Miralles' Architectural Pieces:
Three Exemplary

“Cómo acotar un croissant” is a set of detailed instructions to produce the orthographic projections of a given amorphous object, the croissant of the title, but it is also a real lecture on how objects are deconstructed and reconstructed through the joint effort of perception and imagination on the one hand and form and use on the other (“Because a croissant [...] is meant to be eaten”¹³). The drawing was first published in the magazine *El Croquis* 49-50, in 1991, and consisted in a set of drawings showing the measurements of the croissant in plan and section drawn by Eva Prats and an explanatory text by Enric Miralles plus two b/n pictures of a croissant. The exercise seems simple: after carefully drawing the profile of the croissant following the contour of a photocopy (“always gi[ving] slightly more importance to straight segments than to curved...” as Miralles says), three triangles were inscribed inside, from which different perpendicular lines will measure the profile; the sections (extracted from photographs of the croissant) were easily measured using vertical dimension lines starting in the flat plane of the base.

It is important to emphasize that Enric Miralles always remained within the realms of Euclidian geometry. He did not use complex mathematical types of curves (double and triple curvature curves, splines), but straight and circular segments. Tangents where, then, of the maximum importance. But his architecture was designed (and built) through the superposition of layers of simple geometrical operations and never through the use of computer-like complicated and/or algorithmic geometries. Which, of course, makes his architecture more appealing, since what is complex in it is not the form, always an unexpected result, but the gaze through which the architect makes sense of the world.

Play is at home here in the humorous (and unexpected) approach to the subject and at the same time in the rigorous construction that any play is, clearly shown in the perfectly articulated narrative of the geometric construction of the pastry. Orthographic projection is used to construct a different figure, one that can not only be related to the original croissant but to a set of geometrical measurements that seem to transport directly the standing real object (crispy, fleshy, butter smelling, tasty) into a different media: ink and a Cartesian sheet of white paper. Nothing more distant to the truth, though, since the reconstruction of the croissant is not the freezing up of its form, but precisely the geometrical unearthing of the inside-outside negotiation of its profile —its concave-convex articulation, as Miralles will explain in the accompanying text, is no other thing than the result of a kind of invagination: “A surface wraps over itself and an inside appears, formed by superimposing itself over its outside... then the ends close over themselves, forming the wrapping over which the folds are arranged.”¹⁴ The line that negotiates inside and outside is also the one that gives the clue to its construction: the real croissant is apparently reduced to its inner geometrical structure (the profile accurately measured by lines and numbers), as if by reproducing its shape one can appropriate its “idea”. But only at the price of losing the actual croissant. If we have the “idea” (the general process not only to measure the form, but to reproduce it), we do not have the tasty bun. Nevertheless, the final point of the exercise is not capturing any soul of the object, but developing a systematic approach to the drawing of complex forms, for reproducing them but especially to produce them. Instead of reducing the complexity of the physical world, developing a tool to increase it. Instead of producing a proposition about what the croissant really is (its inner geometrical structure, as if the resistant structure of a building¹⁵), or to pose the problem of the locality of the complex set of events that forms the croissant, establishing a mechanism that deals simultaneously with both.

Consequently, it is less a translation than a negotiation between the real (physical) and the ideal (mental). It has no utility beyond its being made —and of course

13 Enric Miralles and Eva Prats, “Como acotar un croissant. El equilibrio horizontal/How to lay out a croissant. Horizontal equilibrium” in *El Croquis* 49-50 (1991): 241-2.

14 Ibid.

15 J. M. García Fuentes links straightforwardly the drawn triangulation that allows the measurement with resistant structures in equilibrium, and proposes a genealogy of similar forms in the structural solutions taken in different buildings by Enric Miralles. “Equilibrium” seems to be, for García Fuentes, the key element. Even if the graphic connections he establishes with famous Russian constructivist works (Tatlin’s Tower and Ladovski’s Restaurant and landing platform on a cliff, Mart Stam’s version of El Lissitzki’s Cloudhanger) are inspiring, the point to be underlined here is that the quest of all those structures is toward instability (perceptive), rather than toward equilibrium (structural). Of course, both realms should not be confused: the laws of perception and the laws of static do not necessarily coincide. A purely structural analysis of Miralles’ structures is, in any case, urgently needed. See J. M. García Fuentes, “La estructura de un croissant” in *DC Papers* 17-18 “Enric Miralles 1955-2000” (2009): 231-238.

16 Enric Miralles and Eva Prats, “Como acotar un croissant. El equilibrio horizontal/How to lay out a croissant. Horizontal equilibrium” in *El Croquis* 49-50 (1991): 241-2. And the star Miralles introduces here signals a reference to the French poet Francis Ponge: “F. Ponge, Le Grand Recueil”. *Le Grand Recueil* (The Grand Collection) is a three volume collection of poems and prose published by Ponge in 1961. Ponge’s poetry, which Miralles studied in depth and which he loved (as Enrique Granell and Josep M. Rovira explained in different texts, see Josep M. Rovira (ed.), *Enric Miralles, 1972-2000* (Barcelona: Fundació Caja de Arquitectos, 2011) and that does with words, in many ways, something similar to what Miralles does with drawings. More than a detailed phenomenology of what exists (see Ponge’s books *La fabrique du Pré* or *Le Parti Pris des Choses*), or even a tentative of exhaustion of a physical reality (similar to what Quenau or Perec did, authors Miralles also admire and knew in depth) the reference to Ponge seems to lead us to the (impossible) doubling or mimesis of what, in fact, does not exist as an outside of text —as marked for example by the inclusion-exclusion of the author’s proper name at the end of the text as its signature. Jacques Derrida makes the point in *Signsponge* following a three steps movement: since things are mute, it is the author, Francis Ponge in this particular case, the one who “lends” his name to let the things speak through him so to say, under his name and signature. This, of course, erases Ponge’s own signature in favor of the signature of the things proper, since they speak through him. At the end, the two signatures erase themselves, and what rests is neither author nor object, neither Ponge nor the things. The resultant thing-texts re-inscribes itself as the demand of the thing itself, that dictates its own law, before or beyond the inscription, as the absolute demand of the other. What seemed at the beginning a mimetical project, turned to be a destabilizing one that unfolds in the form of a demand, the demand that the thing makes to me. Says Derrida that for Francis Ponge the “thing is not something you have to write, describe, know, express, etc... [...] The thing is not just something conforming to laws I discuss objectively (adequately) or, on the contrary, subjectively (anthropomorphically). Beforehand, the thing is the other, the entirely other [...] the other-thing which gives me an order or addresses and impossible, intransigent, insatiable demand to me.” Jacques Derrida, *Signsponge* (New York: Columbia University Press, 1984), 12-14. In relationship with the question of mimesis see too Jacques Derrida “The Double Session” in *Dissemination* (London: The Athlone Press, 1981).

We do not have space here to develop the implications of this demand now. Suffice to say that a deeper engagement with Ponge and Derrida is necessary to understand Miralles’ architecture that the one given till now.

ideal ideas have no utility beyond its very condition of being unbuilt—, since of course no one will use these drawings to construct, less to bake, a croissant (as Miralles and Prats acknowledge, the restitution will take out the tasteful properties of the croissant: “When measuring it, numbers return transparency to the form, with all its negative qualities* the lack of color, smell and taste”¹⁶). The measuring exercise only tries to *understand* (to unearth sense)—as if understanding a property of drawings themselves, a particular agency of their own, a commitment precisely with their physicality- and *produce* —but produce more ideas (mental propositions). Enric Miralles always made his drawings to understand (which is to find sense in relations) and not to represent; to propose (a new, unexpected set of relations) and not to certify, as a coroner, a given state of affairs. To understand for the architect is both to unearth relationships (from which sense will appear) and to delineate intersections in order to ultimately expose differences (out of which sense arises) in the realm of construction. But never to retrace, or double, or describe an already existing object. Only to intersect with it.

Shortly after the beginning of Stendhal’s famous novel *The Charterhouse of Parma* (1839), in Chapter three, the main character and romantic hero of the novel, Fabrizio del Dongo felt himself immersed, rather inadvertently, in the middle of a chaotic state of affairs. The situation is confusing for saying the least, even chaotic; soldiers galloping in one direction or in other, Generals and Marshals randomly entering and outing the scene, dense white-grayish smoke obscuring the sight, ditches filled with 5 feet of water and soaked fields sweep by bullets, and a tremendous beating noise. The young hero had the illusion of taking part into a real battle, but he only found a senseless succession of quickly passing events, some in the form of a farce, some heroic, some only banal. “Was I really in the battle?” asked himself time after... and yes, he was present, took part, even acted heroically in the battle of Waterloo. But Fabrizio didn’t realize it till many years later. He only felt himself immersed in a sequence of apparently unrelated individual events. Any clear vision of the battle conspicuously absent, Fabrizio couldn’t find any order in what happened, nor even a name for it. He was inside the battle, in the center; he even acted as part of the guard of Marshal Ney and saw not far from him the Emperor himself. But he only perceived disconnected local conditions, fleeting images of horses, bullets, sabers and musketry, soldiers and trees. Seen from inside things seem to be meaningless.

To attach some sense to this state of affairs Fabrizio apparently needed to attribute them its proper name, “the Battle of Waterloo” (and this came time after, when he was *outside*, both in time and space). Then things seem to be clearer, oh yes, he acted heroically at the last battle of the great Emperor Napoleon Bonaparte! And nevertheless... the real meaning of the battle has been lost. The “Battle of Waterloo” is only an effect of the confusing panorama Fabrizio lived, it has no real flesh other than the words in which it is said. The proposition has nothing of what he felt, no reality is in it, no bodies mixing in casual unexpected interactions. Where is the “real battle”? Where the sense then?

For Gilles Deleuze the answer to this question is: neither in the proposition nor in the events that happened, but in the *boundary* between the two. The sense does not exist outside the proposition that expresses it as we have seen (being in the middle of the battle does not guarantee nothing), but at the same time the set of various events that the real battle has has no meaning at all other than the clashing of bodies it was formed by. Writes Deleuze in *The Logic of Sense*: “Sense is both the expressible or the expressed of the proposition, and the attribute of the state of affairs. It turns one side toward things, and another side toward propositions. But it does not merge with the proposition which expresses it any more than with

JOSÉ VELA

Enric Miralles' Architectural Pieces:
Three Exemplary

the state of affairs or the quality which the proposition denotes. It is exactly the boundary between propositions and things.”¹⁷ And adds shortly after: “It is in this sense that it is an ‘event’: *on the condition that the event is not confused with its spatio-temporal realization in a state of affairs*. We will not ask therefore what is the sense of the event: the event is the sense itself.”¹⁸

Sense in Deleuze is then an effect, something constructed-extracted from elements that in themselves have no sense (the state of affairs *and* the proposition that denotes it). And so is the croissant of Miralles and Prats (and, by extension, all Miralles' architecture), constructed as an event, as a constantly negotiated line (or *contour*) that tries neither to describe a comprehensive form (a *proposition*) nor to represent the different simultaneous particular cases (the particularities of the croissant, its taste, colour, smell, touch, structure...). Although this contour line is singular in this exercise (as is the result of an existing reality) in the projective drawings in which Miralles is trying to produce a new design, is easy to see how he delineates this eventful line through a multiplicity of approaching lines, out of which the unexpected (the sense) will appear.¹⁹ The line divides itself in a tentative way, vibrates and oscillates trying to capture the absolute undecidability of the unexpected. And this unexpected, this sense (that is incorporeal in Deleuze vision), is never given in a fully defined, closed form: it is open always to a future to come, but also to a past that is the history of sense itself (a *genealogy*, hence Miralles' genealogy of forms), and consequently is never present as a present. This also means that this line of the event (the sense), has a particular temporality, doubled, disjointed, that is traced, erased and retraced constantly but that at the same time has certain stability. The line is, then, both built and unbuilt. Sense is not given once and forever, it can fall into nonsense quickly, it can be disentangled (when for example seems to coincide with the bodies denoted) to be recomposed once again. Sense is built and unbuilt, in different temporalities, but at the same time.

The “croissant” and the drawings are not commensurable, although both are coexistent parts of the given state of affairs. The drawings made by Miralles are less exploratory tools than geometrically constructed lines of flight,²⁰ lines that allow the construction to interrelate with other constructions in the production of multiplicities in an indeterminate and unpredictable but nevertheless possible-real here and now. The important thing is how things connect (in the sense that a singer “connects” with his audience), and this is what Miralles' drawings accomplish: a whole (new) set of connections. Miralles' drawings are not a wholly different thing than connecting lines. Nor less. Even the “objective” dimension of the croissant —but not the Cartesian geometrical ones. Says Miralles: “Let the constellations of centerpoints appear without forming any relation between them, except the ordering of succeeding tangents at a common point”²¹ and what he is pointing to is to the discovering of prior unperceived connections instead to the imposition of a fixed, pre-existing, numerical relations.

For Miralles geometrical projections do not translate reality into a drawing (a different media) as the ancient myth of Dibutades seemed to imply —a memorabilia of what is not, and cannot be, present anymore. Neither are they instrumental tools to reconstruct, to “retranslate” back to reality a previous formal arrangement. They exhaust in themselves, ideal-unbuilt-real drawings, as if in the act of discovering discoverer and discovered finally coincided. Drawings in Miralles have an agency of their own, nor instrumental, secondary, translative, “modern”, from ideas to buildings. Neither subjective nor objective, they pertain to the category of the processual, always on the act of becoming objects, always on the verge of

17 Gilles Deleuze, *The Logic of Sense* (London: The Athlone Press, 1990), 22.

18 Ibid.

For further discussion on sense and event in Deleuze, apart from his *Logic of Sense*, see the voices “event” and “incorporeal” in Adrian Parr (ed.), *The Deleuze Dictionary* (Edinburgh: Edinburgh University Press, 2010). See too François Zourabichvili, *Deleuze. A Philosophy of the Event. Together with the Vocabulary Deleuze* (Edinburgh: Edinburgh University Press, 2012) and John Rajchman, *The Deleuze Connections* (Cambridge, Mass. and London: MIT Press, 2000). Also see Smith, Daniel and Protevi, John, “Gilles Deleuze”, *The Stanford Encyclopedia of Philosophy* (Winter 2015 Edition), Edward N. Zalta (ed.), forthcoming: <http://plato.stanford.edu/entries/deleuze/>

19 In a beautiful explanatory sequence of images and texts Miralles wrote for the German flower magazine *Bloom*, this multiple bundle of lines-boundaries seems to be explained as follows: “The paths approach each other... / and though they don't cross, / they do walk side-by-side for a while... / This approaching and separation / is a model of growth that is also found / in the growth of plants... / due to this effort to meet... / the leaves and flowers seem to us —often- / as an unexpected outcome.” Flowers (sense) appear in this “approaching separation.” In Benedetta Tagliabue (ed.), *EMBT. Enric Miralles Benedetta Tagliabue Work in Progress* (Barcelona: Col·legi d'Arquitectes de Catalunya, 2004), 11.

20 It should be remembered that French “fuite” which Deleuze uses in “ligne de fuite” has the following meanings “fleeing or eluding but also flowing, leaking, and disappearing into the distance.” Brian Massumi, “Notes on the Translation and Acknowledgments.” In Gilles Deleuze and Félix Guattari, *A Thousand Plateaus* (Minneapolis, MN: University of Minnesota Press, 1987), XVI. The lines of Miralles are, of course, flowing and leaking, and they, sometimes, even disappear into the distance...

21 Enric Miralles and Eva Prats, “Como acotar un croissant. El equilibrio horizontal/How to lay out a croissant. Horizontal equilibrium,” in *El Croquis* 49-50 (1991): 241-2

[Fig. 3] Enric Miralles. Mesa InesTable/ InesTable table. 1993.

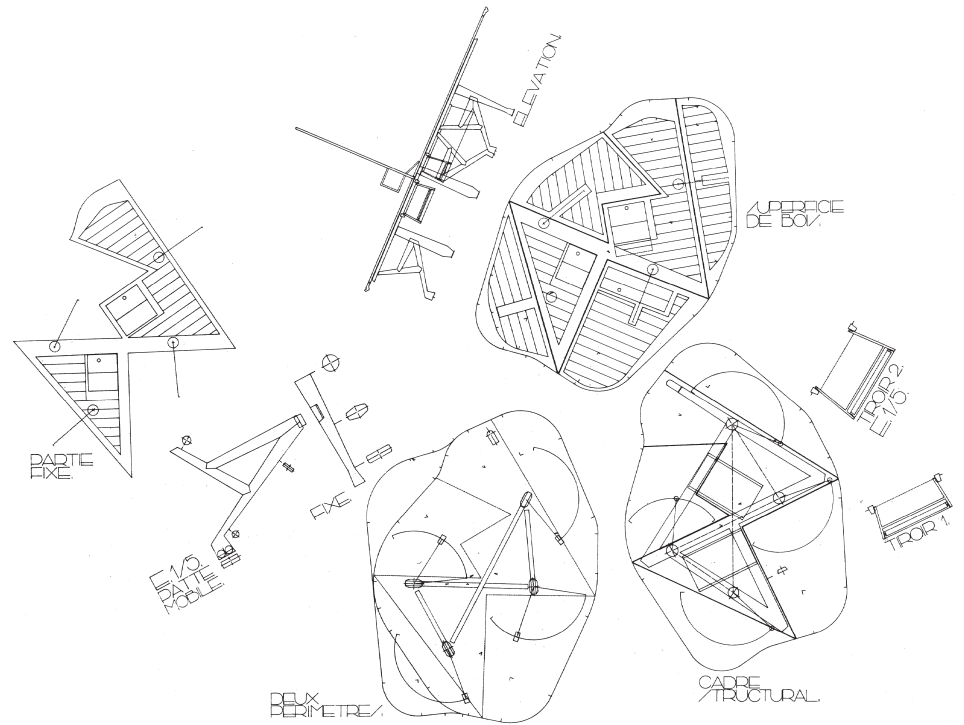

informing them (are drawings the subjects of buildings rather than those, finished or unfinished, are the subjects drawn in drawings?), but always on the move, fleeing.

“How to Lay Out a Croissant” is the place in which Miralles articulated theoretically, at the level of drawing, the tools that will allow him to think his architecture. The two coordinated sets of geometrical families, segments of arches and triangles, set the basis for the graphic-constructive explorations of the office, and established the reversible movement between construction and deconstruction or building and unbuilding. The precise system here evidenced is a powerful mechanism that allows either to map what exists or to design what does not exist yet. It works both ways, undoing perceptual reality (the croissant) or explaining the produced reality. Not surprisingly, the witty idea behind the exercise came almost inadvertently as a joke, as the result of the daily work at the office —and not as a foreign theorization alien to the real work with drawings. Eva Prats, then working at Miralles’ office, recalled years later how she was dimensioning the platform of a spiral stair in the project for a Civic Center in La Mina (1987-93). The curved form needed precise measurement for its construction, and Prats came across the idea of placing a triangle inside the curved form, and from each side of the triangle the shape was easily defined. Miralles saw the drawing and exclaimed: You can measure everything... you can measure a croissant!²² [figure 3]

“Mesa InesTable” —a pun between the Spanish word for instability and the English word table that results in a description of its fundamental undecidability, but that introduces in the equation too the Spanish name Inés (Agnes) providing the table with a certain anthropomorphic quality, common to many Miralles’ designs²³— was a commission from the French CNAC - *Le Magasin* for a joint exhibition with other young architects held at Grenoble between May and August 1993 under the title “Application & Implication – modèle de pensée et actes de presence / jeunes architects en Europe.” The proposal asked the architects to build for the exhibition a small piece explaining their way of thinking, and the answer Miralles gave was this piece of furniture. Only three exemplars of the table exist today: one in Enric Miralles and Benedetta Tagliabue’s own house in Carrer dels Mercaders, a second one in EMBT’s office at Carrer de la Pau and a third one, the last to be made, at the Palafolls’s Public Library. The piece is a table the size of a room²⁴

22 Eva Prats and Ricardo Flores, “Las tardes de dibujo en el estudio Miralles&Pinós” in Enric Miralles Αρχιτέκτονας (Greece: Επίκεντρο, 2014), 94-101. Translated by the author. Published online in: <https://homenajeaenricmiralles.wordpress.com/2015/09/09/eva-prats-y-ricardo-flores-rememoran-a-enric-miralles/> Retrieved October 25, 2015.

23 As for example Enrique Granell detects in the model for the Círculo de Lectores (Madrid, 1991) when put vertically: “I follow on my mania of turning upside down the plants. It is not difficult to recognize in Círculo’s plant the shape of a person, with his big head, his nose and mouth.” See Enrique Granell, “Una maleta llena de arquitectura” in Josep M. Rovira (ed.), *Enric Miralles, 1972-2000* (Barcelona: Fundación Caja de Arquitectos, 2011), 55. Translation by the author.

24 It is roughly 3,00 by 2,80 meters.

JOSÉ VELAEnric Miralles' Architectural Pieces:
Three Exemplary

[Fig. 4] Enric Miralles. Mesa InesTable/
InesTable table. Fotografía/Photographer:
Giovanni Zanzi

that can be moved, folded in parts or rotated, and that reacts to and interacts with the user in many —some unexpected— possible ways (for a table). In fact it forms a kind of landscape of events in itself —it seems to change every day as subjected to time and weather conditions or to affective momentum of the users— radically transforming the space in which it is settled —and the user. But it is also a compound of architectural ideas to be tested in the uncompromising space of domesticity. The table is certainly solid, even steady, and is made of solid oak, which is a pretty good statement about its materiality. It needs to be so, to admit the different movements, positions and configurations it performs, to allow to play with it without destroying its (pr)esence. But nevertheless, it looks impermanent, as in a constant path toward a final form never to be reached. All this meaning that its instability has to come from a different source than the structural one (same case that the croissant).

The table, a table, is always expecting something, someone, an object, a person or an event to fulfill its role, to explain its purpose, to be a table, to serve as a table. InesTable profits of this basic quality of tables —the basic quality of a tool: that of its impermanence.²⁵ Of the intermittence in satisfying the demands for which has been built. Similar to what happens to Miralles' designs in general, but with a physical capacity of its own, the table is never finished, is always in the verge of changing its configuration, is actively transforming physically in itself —and its environs. It unbuilds the space around it, deconstructing the given stability of any architecture in which is inserted: questioning the given assumptions of what an interior is, what the uses for a table are, which the appropriate places for a table to stay in, even physically altering its own form. [figure 4]

The form of the table is given at a general basic stratum, but it can —or should— be transformed by the active engagement of the user. The table, being finished (as said, it is a carefully crafted piece of solid oak, like an old work of carpentry, a bourgeois *escritoire*), is nevertheless changing. Like the wings of a tropical insect the platform of the table unfolds into a manifold. Like the secret chamber in a burial hidden pockets and drawers reveal untold secrets. Like a mechanical puppet express and dissolves the personality of the puppeteer, an artificial

²⁵ Tools are only “true” tools in the moment they are being used, hence its impermanence.

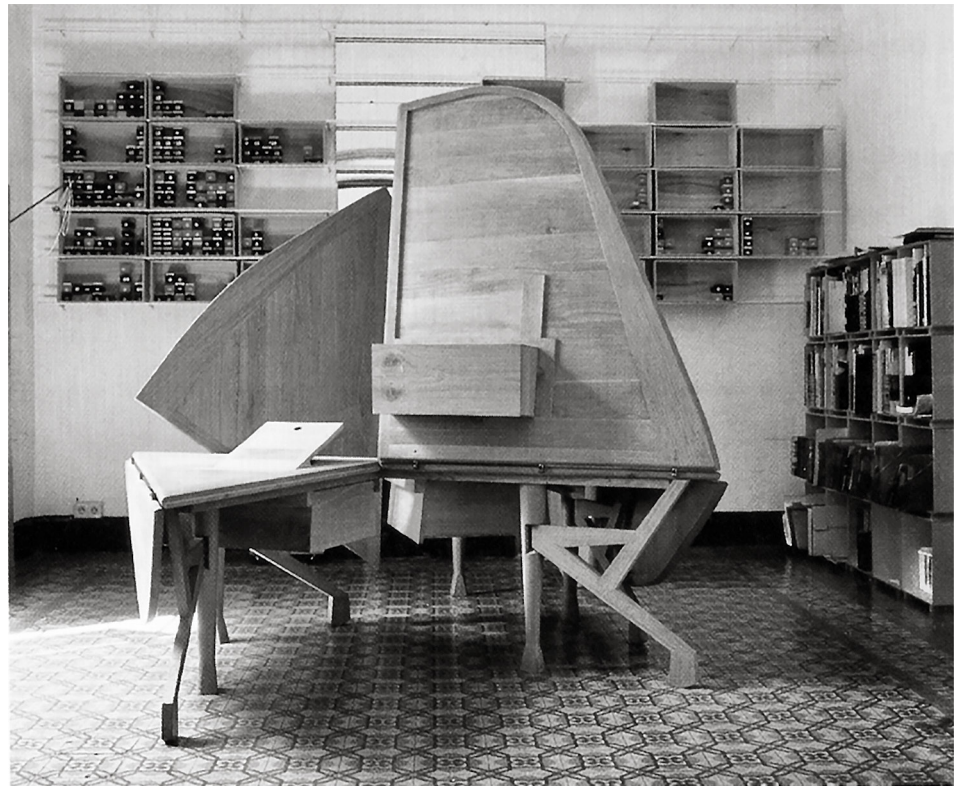

[Fig. 5] Enric Miralles. Mesa InesTable/
InesTable table. Fotografia/Photographer:
Giovanni Zanzi

movement becomes natural. It is the very incarnation of Miralles' love for unfixed and unfinished projects, for architecture always deferred, always to come, always expecting someone, something, somewhere —to happen. The table is not built, but only performed. That is its essence, if an essence should be. That is its idea: it's not being identical to itself. Its being multiple tables at the same time. And although not all of them are actual, they are nevertheless present as virtualities. The following quotation by Miralles is revelatory: "I never work by reduction: I try to reveal the multiplicities, the singularities..."²⁶ InesTable is singular and the same time plural, multiple. It reveals —even if it not actually unfolds them— the virtual capacities it has. Yet actual and virtual are not oppositions in InesTable, nor in Miralles' architecture in general. The virtual can be actualized in many different ways, yet this actualizations neither exhaust nor coincide with the virtual that hovers over them. InesTable, in its generous expenditure, acts as unending reservoir —of future untold events. [figure 5]

26 Enric Miralles in Alejandro Zaera-Polo-Polo, "A conversation with Enric Miralles", *El Croquis* 72 [II] (1995): 18.

27 We allude here to the famous piece Joseph Beuys performed in 1974 at the Rene Block Gallery in New York called "I Like America and America Likes Me." In it, Beuys shared a room with a wild coyote in periods of 8 hours a day during three days of May 1974; in the room only a blanket and a pile of straw. Beuys was among the influences that Enric Miralles quotes linked with InesTable. For example he referred directly to one ink drawing by Beuys—"Female Artiste" 1950-51— in his lecture at the Menendez Pelayo University to explain the ideas of "labyrinth" and "border" behind the InesTable, and to insist in that things can only be described through the way they are done (but not *explained*): "I think it is explained very well in this drawing. This is a drawing by Joseph Beuys. It can only be described through how it is done." *DC Papers* 17-18 "Enric Miralles 1955-2000" (2009): 20.

InesTable has an agency of its own, as a table and as much more and slightly less than a table. It is a table but also a non-table, and it is necessary to play with it to discover and/or to enforce its radical playfulness: it demands the engagement of the user —or the spectator. It is a non-table too, since tables are to hold things on, but this particular one seems to be conceived more to lift things up in the air (or to make them vanish into its belly) than to resist down the weight of ordinary things —and habit. More a workbench and a peasant drawer (both terms are here absolutely compatible) than a roundtable to sit around (and to impart law from it: InesTable destroys any possible hierarchy even if it creates privileged spots), it produces an unrest not so dissimilar to the one Beuys could have sensed when the Coyote was around (unexpected, untamed, fierce, but reassuring at the end).²⁷ Or Saint Jerome (Hieronymus), as depicted in the famous painting by Antonello da Messina (St. Jerome in his Study, 1474-5), sitting in and reading calmly while the space of the canvas is populated by various disturbing creatures, a lion, a peacock, a cat, a partridge, some bad omen flying birds... Josep M. Rovira directly links InesTable with this painting, establishing the connection via the capacity of the table of creating an interior *inside* and interior (the studio of the Saint is an open wooden construction in the nave of a Gothic church of Catalan-Aragonese inspiration). The

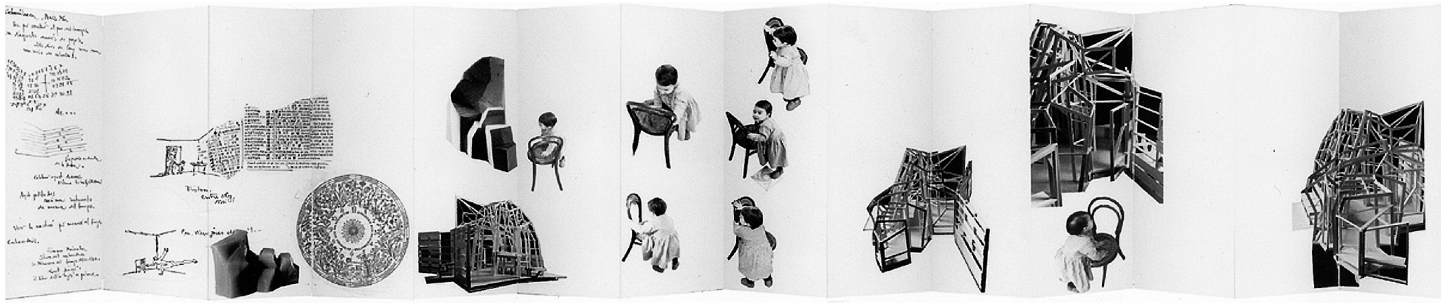

[Fig. 6] Enric Miralles y Benedetta Tagliabue. *Kolonihaven*. 1996. Collage.

overdimensioned cupboard in which the Saint reads and writes fulfilling different roles as table, drawer, bookshelves etc. and at the same time isolates and protects him.²⁸ Architecture inside architecture inside architecture, as Juan José Lahuerta reminds us alluding to this same picture discussing Miralles.²⁹ But the important point is the construction of an interior space precisely un-building another interior space. The table, as a portable architecture, transforms every interior space into an exterior, securing for itself the role of the interior, effectively ruining any stability of the preexisting space. The table produces the ruin of the interior, leaving exposed to the sky, to inclement weather and wild beasts the skeleton of architecture. It literally unbuilds the space, opens up to an exteriority the same way that the passing of time unbuilds an old monastery, exposing the pudenda to the usury of time. InesTable delimits an architecture of its own, a protective interior space that, at the same time, is the limit of an exterior space, an spaces that invaginates as the croissant has done. Miralles himself explains this operation when he says: “The only interior place I ever built would be the table I told you about [InesTable]. It is a table that can be in any corner [of a building]. It allows you ‘to live’ inside, but not ‘to be’ inside.”³⁰

In 1992 Miralles was asked to write a short text about the furniture designed by Allison and Peter Smithson for the magazine *Arquitectura*. He proposes to review the pieces from the point of view of the material from which they are made and the place for which they are designed. He affirms its “ordinariness” as the way to qualify the subtle way they engage with the daily life in the places they are precisely placed, focusing on the possible movements through space —as in the case of *Trundling Turk* armchair inside the Smithson’s house. When it comes the turn to deal with *Fish Table*, he describes it, in his memories, as a place in which many different objects collide (it has “the strangeness of a sewing machine” and its glass surfaces allow to “surprise ourselves with the vision of our shoes among the collected objects, or the fingers that are already fish...”) and he affirmatively writes: “It is a machine of transformations...”³¹ This, of course, is a more than apt definition of his own table (mind that the text is written only the following year to the design of InesTable). And, of course, he was right. InesTable is a real machine of transformations: it transforms itself and transforms what is around, transforms time and space, transforms extension and duration, and converts what is finished into unfinished. It is a machine to produce events. Hence, I can say: the table *tables*, as if in the action of this improbable verb a transformation of what we think a table is is reassessed and negated at the same time, its utility put into question precisely by its very essence as a productive tool. In Miralles’ words: “It is a working tool and at the same time a thinking tool, this is what I would like my buildings to be”.³² What will allow us the table to think that is inseparable of its being a table, of its utilitarian dimension, of its material composition, of the complex net of social habits and impersonal agencies in which it is immersed and which stubbornly transforms? Precisely the transitivity of every architecture, its constant process of being built and unbuilt, its own impersonal agency. [figure 6]

28 Josep M. Rovira, “Enric Miralles. Otros proyectos 1990-1994” in Josep M. Rovira (ed.), *Enric Miralles 1972-2000* (Barcelona: Fundación Caja de Arquitectos, 2011), 240.

29 Juan José Lahuerta, “De momento” in Juan José Lahuerta and Benedetta Tagliabue, (ed.), *Enric Miralles. Obras y proyectos*. (Milán: Electa, 1996), 18-19.

30 Enric Miralles in “Acceder”, lecture at the Menendez y Pelayo University, July 19 and 23, Santander 1993. As quoted in Josep M. Rovira (ed.), *Enric Miralles 1972-2000* (Barcelona: Fundación Caja de Arquitectos, 2011), 87. The full text of this lecture has been transcribed and published in *DC Papers 17-18* “Enric Miralles 1955-2000” (2009): 19-32. Translated by the author.

31 Enric Miralles, “On the Trundlink Turk,” *Arquitectura* 292 (1992): 87-88.

32 Enric Miralles, “Acceder” in *Revista del Consejo Superior de Colegios de Arquitectos de España* 132 (1994): 58. Translation by the author.

[Fig. 7] Enric Miralles y Benedetta Tagliabue.
Kolonihaven. 1996. Planta/plan.

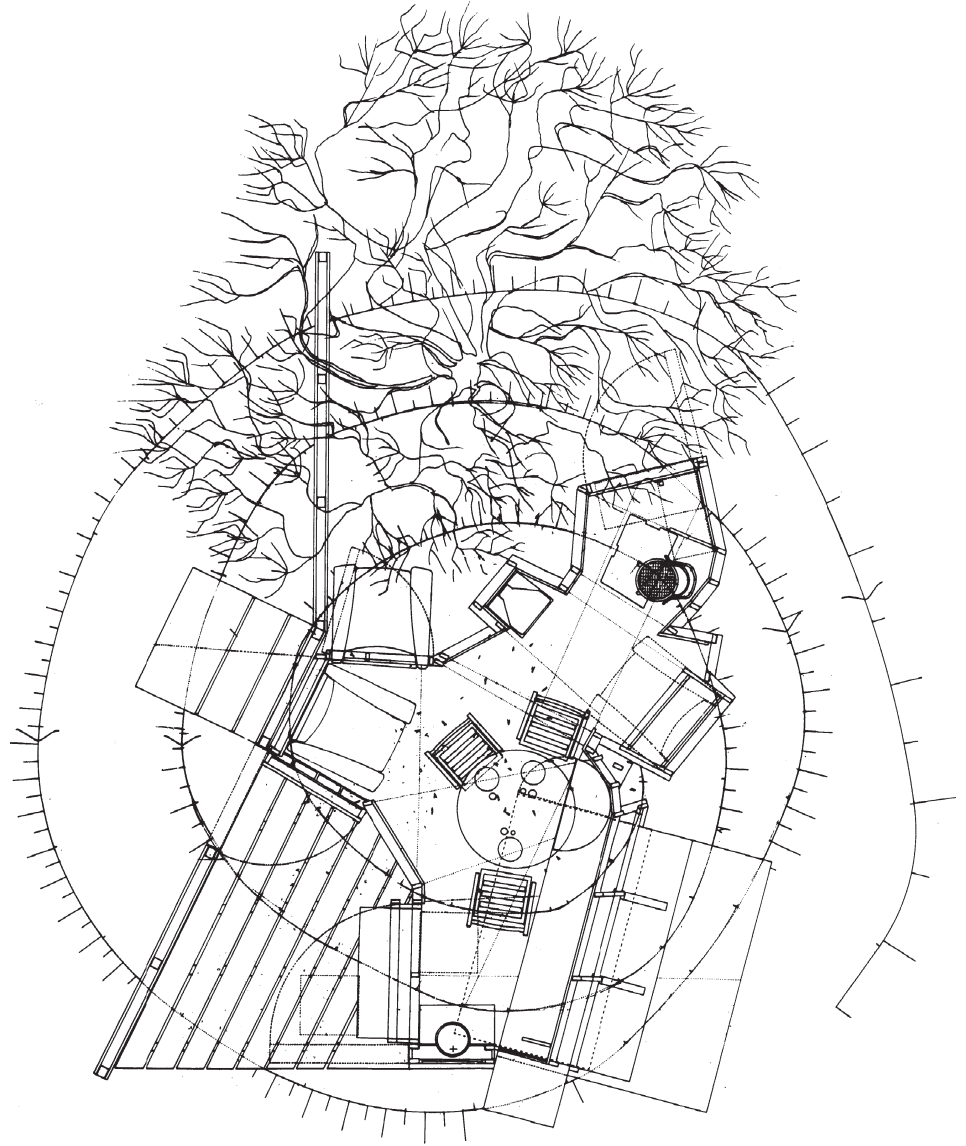

Kolonihaven is a small “house” commissioned by Arcspace in 1996 for an exhibition in Copenhagen, Denmark, that reunited thirteenth architects to reinterpret the Kolonihavenhuis. Kolonihavenhuis are the tiny little houses built on small gardens in the outskirts of many Danish cities for people to spend their free time in gardening and/or in contact with nature. Miralles’ design for this small house, that he called Kolonihaven, is based on two complementary ideas: the idea of the passing of time —hence the collage Miralles concocted for the final presentation using a calendar and a German botanical book showing the time of flowering of different species— and the idea of playing —the layout of the plan, and even the volume, it is said, responds to the movements Miralles’ young daughter made playing with a toy-chair at home; the overall shape of the section designed as a “dress” that covers the figure of a bending adult sitting inside the small house. This relationship with children play and with playing in general goes beyond a question of shape, and articulates a slanted dialectic between ideas and construction: play —and games— are based in a given set of rules that, nevertheless, do not determines any particular given form, neither impose any charged meaning on them: the result is an open relational field in which every time the game is played, the construction is made differently, erasing in this way the very idea of a preexistent ideality and a finished construction. [figure 7]

The project was finally not realized for the exhibition in Copenhagen and it remained unbuilt. Nevertheless, years later, in 2001 (the architect died in 2000), a different version was developed and built to be exhibited at the MACBA in Barcelona in

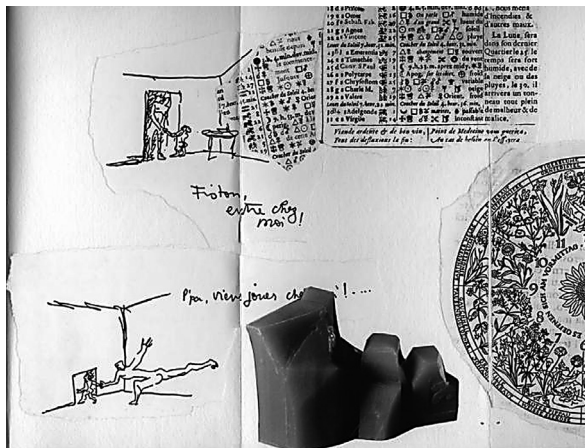

[Fig. 8] Enric Miralles y Benedetta Tagliabue. *Kolonihaven*. 1996. Collage (detalle/detall).

[Fig. 9] Enric Miralles y Benedetta Tagliabue. *Kolonihaven*. 1996. Maqueta de jabón/Soap model.

[Fig. 10] Enric Miralles y Benedetta Tagliabue. *Kolonihaven*. 1996. Planta. Maqueta de madera/Wooden model.

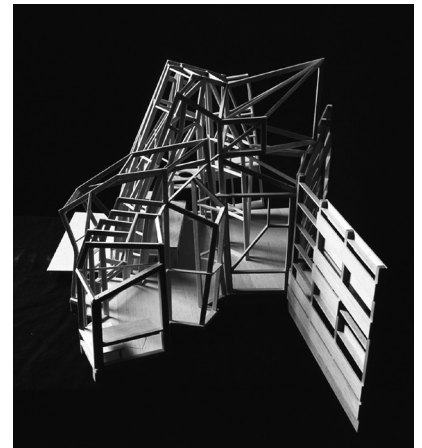

2002, and was later moved as a children playground to the Diagonal Mar Park, also designed by Miralles and Benedetta Tagliabue. Its troubled life did not end up here, and after being vandalized and burned, in 2004 was restored and moved to a destination in the gardens at the Palacio Pedralbes. Owned by the Museu de les Arts Decoratives (Museum of Applied Arts), it has been transformed into a piece of art, a work to be contemplated instead a piece to be played with.³³ The opposite of any building, and especially Miralles' ones, should be.

As said, inspiration for the design came from the movements his daughter made when playing. In addition, Miralles cites as source a drawing by Le Corbusier that can be found in *The Modulor 2*,³⁴ in which a child with his father are alternatively standing in the threshold of a door adult size and trying to enter a tiny door opening children size (in which only the child succeeds). Le Corbusier caption reads "P'pa, viens jouer chez moi!..." and "Fiston, entre che moi!" The child is playing, but the father is serious, trying to teach his child the social conventions. Curiously, Miralles cuts and paste le Corbusier drawing inverting the sequence in the *collage* he made for the *Kolonihaven* [figure 8]. The children play define a space of its own, in which size and scale are two fundamental considerations. But it also creates a different perception of time, and this was also included in the design: the different sizes and heights of the spaces seem to condensate under one single volume the different ages through which the child will pass to transforms himself into an adult. The link between both ideas, the passing of time (in a closely phenomenological way) and that of playing (and it is not only a question of children play) can of course relate this design to others if not all Miralles' designs, and finds its power in the intersection between a general agency of playing and a question of performance.

True, the final design of the plan for the *Kolonihaven* seems to be at first sight the simple deployment of a cartography of movements (of the child) through time, which is to say the freezing of what is basically an ongoing process. Playing and performance seem to be excluded from the result, but precisely because it is an unbuilt design, the dialectics between fixed and open opens up again. Performance is again reintroduced into the piece through two distinctive ways. On the one hand, performance as the implementation of responsive qualities (in the sense it is used now in the advertisement of sport and outdoor clothes), as an active response to the changing conditions of both weather and physical activity, is embedded in the skin of the small house, that will act as surface of interchange and interaction rather than an isolating membrane and that incorporate a novel politics of the envelope. In the different stages of the design, the skin of the house changed constantly, adopting many forms and configurations. The initial conceptual model, made carving a piece of soap by Miralles himself, showed a surface that looks like a cloth that dimly separates interior and exterior (the shoulders of the protective father seem to hold this translucent canvas) [figure 9]; the wooden models for the Copenhagen exhibit

33 For a chronicle of the different lives of the piece, see the following webpage: http://w10.bcn.cat/APPS/gmocatleg_monum/FitxaMonumentAc.do?idioma=CA&codiMonumIntern=2069. Retrieved December 16, 2015.

34 It can be found in page 93, fig. 3. Le Corbusier, *Modulor 2: La parole est aux usagers*. (Boulogne-Billancourt: Éditions de l'Architecture d'aujourd'hui, 1955), 93.

a more opaque and faceted surface. In the structural wireframe models the skin disappears and the house is open to the sky, as in the version of the piece actually built in Barcelona. [figure 10]

On the other, performance enters via Taylorist studies on efficiency of the worker's movements, as in Soviet "choreographies of movement", precisely to be radically subverted by Miralles' design.³⁵ It is not efficiency which gives the final form of the house; it is not a process of optimization or a scientific organization of children's play and social conventions which guarantees (and assigns) the places and times for each activity (labor) made. The tiny house is not a glove that fits perfectly the space chartered by the movements of the child when playing. As Fabián Asunción says: "The point is not to create a train's capsule."³⁶ The point is not to optimize the space as a mimetic space, one that perfectly encapsulates and reproduces the now codified movements of the children, but precisely the opposite, to open the space to as many possibilities as possible, to transform the space into an unfinished place, in which play is serious and meaningful activity and not useless nonsense. Time, although ruled by the calendar, is not measured by a clock but precisely by the activities the child does when playing, that have a temporality of their own. And the activities are daily life ones, the ordinary play of life put into action: since the piece is a small house, there are areas for different living activities and accordingly spaces of different heights —for lying, for sitting down, for standing up— and shapes. But the house is not only for children, as we have seen: an adult can also enter in, but for him, Gulliver in Lilliput, the place when seen from the inside, is rendered meaningless —and uncomfortable. The children play under the protection of the father, but the father is excluded from the game.

The piece embodies the radically free and without purpose act of playing. It is the proper agency of playing which subverts the techno scientific and economic categories of performance studies to introduce sheer performativity. And are the twisted conventions of Alice staring at us from the other side of the mirror and not the fossilized economic principles of production optimization the ones that reintroduces freedom and fiction into the mix. Because play has no use, no profit perspective, no purposiveness beyond itself, no foreseeable construction. It is unproductive. And it remains, as in the play of children, always unfinished.

What the little house produces at the end is the definition of a field, a frame inside which play can happen. It delineates, as the croissant but in a more sophisticated way, the moving boundary that is the intersection that defines events as having sense, masterfully exploring the tension and balance that happens according the framework that delimitates play. Improvisation and rule observance make at the same time possible and impossible to play: the outcome of the play remains unforeseen. And this is what really interests Miralles.

Playing establishes a secluded time and space and with them a set of different conventions that rule inside this separated environment, and this is what Miralles achieves in his design: more than constructing a small building he establishes a place in which new rules apply, but in which uncertainty reigns too, in which there are room, one and time again, for new ideas to rest unbuilt. By defining shape as the double coded figure negotiated by children movements —free and unexpected but mapped in a productivistic way— and ordinary time —everyday life of the father that is necessarily set aside of the interior space— Miralles is establishing a new territory in which the tension between what is predictable (according to the new rules) and what is improvised (according to the innermost necessity of play) unleashes the freer energy of architecture. Inside this newly produced space and time, everything can happen, although at the same time everything must happen

35 See for example Ross Wolfe, "The ultra-Taylorist Soviet utopianism of Aleksei Gastev; Further notes on Taylorism and socialism", *The Charnel House* blog, 7 Dec 2011. <http://thecharnelhouse.org/2011/12/07/the-ultra-taylorist-soviet-utopianism-of-aleksei-gastev-including-gastevs-landmark-book-how-to-work>. Retrieved July 27, 2015.

36 "Otras narraciones... Entrevista a Fabián Asunción" in *DC Papers 17-18 "Enric Miralles 1955-2000"* (2009): 109. Translation by the autor.

JOSÉ VELA

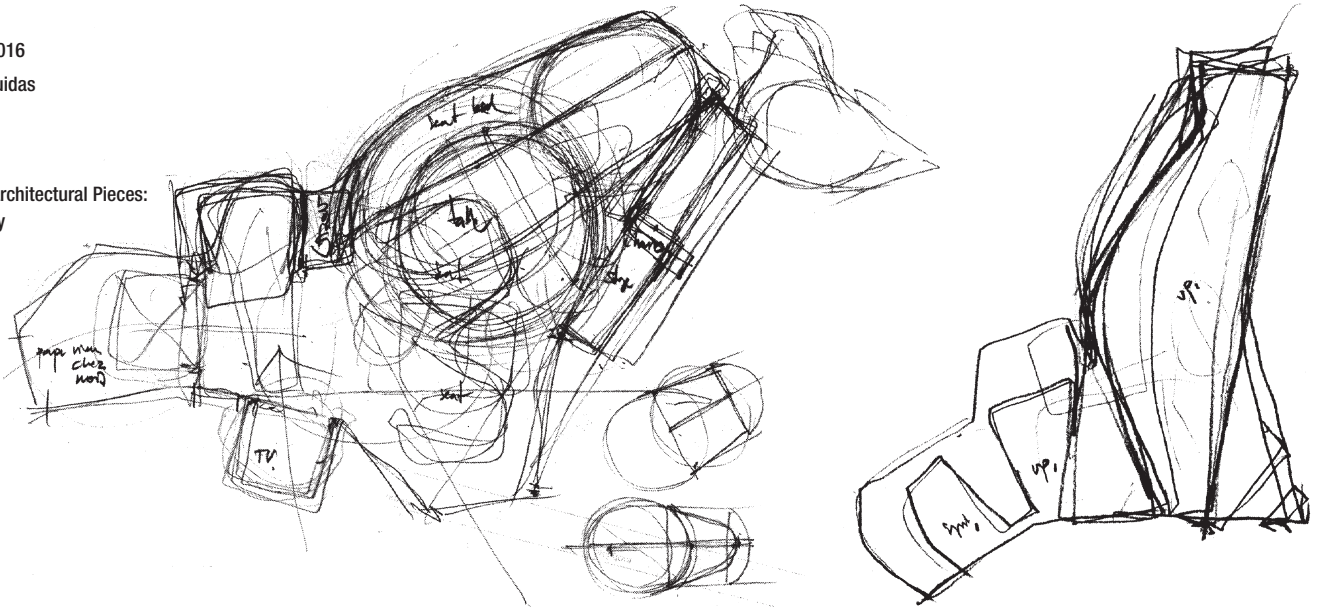
Enric Miralles' Architectural Pieces:
Three Exemplary

[Fig. 11] Enric Miralles y Benedetta Tagliabue. *Kolonihaven*. 1996. Croquis de planta/Sketch for the plan.

[Fig. 12] Enric Miralles y Benedetta Tagliabue. *Kolonihaven*. 1996. Croquis de sección/Sketch for the section.

inside the given set of rules. Reenacting the actual/virtual movement of all his architecture, not everything is possible inside this space of playing and playing production, but nevertheless and infinite number of possibilities is open to the players. In that sense, *Kolonihaven* fulfills its role as a model for bigger and more complex architectural enterprises. The building remains unbuilt since its actual form is only one of the unending built possibilities unleashed by the virtual agency of playing. [figures 11 and 12]

Unconclusion

The abstract for this paper put it bluntly: there are no conclusions to be expected from this text, or at least no conventional conclusions. Conclusions imply finished constructions and fixed buildings, deductive structures that could be drawn in the form of proven thesis, sequence of events that, step by step, construct a determined conception of a closed finished object. And, of course, this will kill the game. Nevertheless, a final point needs to be remarked: what Miralles' architecture does in the most perfect imaginable way, and what this paper tried to cast a glance upon —tentative as it is— is the impossibility of speaking about ideas and constructions as two different things, or put in a different way: either Miralles' architecture is never constructed —for many buildings he ever built— or architectural ideas doesn't exist detached from its physical construction, be they a drawing, a model, an architectural piece or what is commonly known as a conventional building —which in his hands are never conventional (yet full of conventions). In that sense, and in that sense only, it is possible to speak of exemplar architectural pieces: as paradigmatic actual constructions that are at the same time multiplicities. Multiplicities that open up the realm of the virtual as the not yet built and, nevertheless, present in its exemplary condition.

Acknowledgements

Thanks to Gavin Keeney, generous as always

References

BAILEY Gill, Carolyn (ed.). 1996. *Maurice Blanchot. The Demand of Writing*. London and New York: Routledge.

BLANCHOT, Maurice. 1969. *L'Entretien infini*. Paris: Gallimard and NRF.

- DC Papers 17-18 "Enric Miralles 1955-2000." 2009.
- DELEUZE, Gilles. 1990. *The Logic of Sense*. London: The Athlone Press.
- DELEUZE, Gilles and GUATTARI, Félix. 1987. *A Thousand Plateaus*. Minneapolis, Mn: University of Minnesota Press.
- DERRIDA, Jacques. 1981. *Dissemination*. London: The Athlone Press.
- DERRIDA, Jacques. 1984. *Signsponge*. New York: Columbia University Press.
- El Croquis* 49-50. 1991.
- El Croquis* 72 [II]. 1995.
- El Croquis* 100-101. 2000.
- El Croquis* 144. 2009.
- LAHUERTA, Juan José and TAGLIABUE, Benedetta (ed.). 1996. *Enric Miralles. Obras y proyectos*. Milán: Electa.
- LE CORBUSIER. 1955. *Modulor 2: La parole est aux usagers*. Boulogne-Billancourt: Éditions de l'Architecture d'aujourd'hui.
- MIRALLES, Enric. 1992. On the Trundlink Turk. *Arquitectura* 292: 85-88.
- MIRALLES, Enric. 1994. Acceder. *Revista del Consejo Superior de Colegios de Arquitectos de España* 132: 58-59.
- MIRALLES, Enric. 2014. Αρχιτέκτονας. Greece: Επίκεντρο.
- PARR, Adrian (ed.). 2010. *The Deleuze Dictionary*. Edinburgh: Edinburgh University Press.
- ROSS WOLFE, "The ultra-Taylorist Soviet utopianism of Aleksei Gastev; Further notes on Taylorism and socialism", *The Charnel House* blog, 7 Dec 2011. <http://thecharnelhouse.org/2011/12/07/the-ultra-taylorist-soviet-utopianism-of-aleksei-gastev-including-gastevs-landmark-book-how-to-work>. Retrieved July 27, 2015.
- ROVIRA, Josep M. (ed.). 2011. *Enric Miralles, 1972-2000*. Barcelona: Fundación Caja de Arquitectos.
- SMITH, Daniel and PROTEVI, John. 2015. "Gilles Deleuze," in Zalta, Edward N. (ed.). *The Stanford Encyclopedia of Philosophy*. <http://plato.stanford.edu/entries/deleuze/>
- TAGLIABUE, Benedetta (ed.). 2004. *EMBT. Enric Miralles Benedetta Tagliabue Work in Progress*. Barcelona: Col·legi d'Arquitectes de Catalunya.
- VELA CASTILLO, José. 2011. El tiempo de la arquitectura: ruina, archivo, fecha. *Iluminaciones* nº 3: 36-47.
- ZOURABICHVILI, François. 2012. *Deleuze. A Philosophy of the Event. Together with the Vocabulary Deleuze*. Edinburgh: Edinburgh University Press.